

TB 9-6625-2071-35

CHANGE 6

DEPARTMENT OF THE ARMY TECHNICAL BULLETIN

CALIBRATION PROCEDURE FOR FREQUENCY COUNTER, AN/USM-459 (TS-3662/U) AND HEWLETT-PACKARD, MODELS 5328A/H42, 5328AMOD, 5328AF096, AND 5328A W/OPTIONS

Headquarters, Department of the Army, Washington, DC
20 June 2001

TB 9-6625-2071-35, dated 24 April 1984, is changed as follows:

1. Remove old pages and insert new pages as indicated below. New or changed material is indicated by a vertical bar in the margin of the page.

Remove pages

9 and 10

Insert pages

9 and 10

2. File this change sheet in front of the publication for reference purposes.

By Order of the Secretary of the Army:

ERIC K. SHINSEKI
General, United States Army
Chief of Staff

Official:

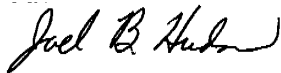

JOEL B. HUDSON
Administrative Assistant to the
Secretary of the Army
0115602

Distribution:

To be distributed in accordance with IDN 342215, requirements for calibration procedure TB 9-6625-2071-35

TB 9-6625-2071-35

CHANGE 5

DEPARTMENT OF THE ARMY TECHNICAL BULLETIN

CALIBRATION PROCEDURE FOR FREQUENCY COUNTER, AN/USM-459 (TS-3662/U) AND HEWLETT-PACKARD, MODELS 5328A/H42, 5328AMOD, 5328AF096, AND 5328A W/OPTIONS

Headquarters, Department of the Army, Washington, DC

13 November 2000

TB 9-6625-2071-35, dated 24 April 1984, is changed as follows:

1. Remove old pages and insert new pages as indicated below. New or changed material is indicated by a vertical bar in the margin of the page.

Remove pages

1 and 2
9 and 10
11 and 12

Insert pages

1 and 2
9 and 10
11 and 12

3. File this change sheet in front of the publication for reference purposes.

By Order of the Secretary of the Army:

ERIC K. SHINSEKI
General, United States Army
Chief of Staff

OFFICIAL:

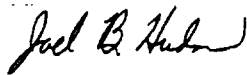

JOEL B. HUDSON
Administrative Assistant to the
Secretary of the Army
0028402

Distribution:

To be distributed in accordance with IDN 342215, requirements for calibration procedure TB 9-6625-2071-35

PIN: 051013-005

TB 9-6625-2071-35

CHANGE 4

DEPARTMENT OF THE ARMY TECHNICAL BULLETIN

CALIBRATION PROCEDURE FOR FREQUENCY COUNTER, AN/USM-459 (TS-3662/U) AND HEWLETT-PACKARD, MODELS 5328A/H42, 5328AMOD, 5328AF096, AND 5328A W/OPTIONS

Headquarters, Department of the Army, Washington, DC
13 September 1989

TB 9-6625-2071-35, 24 April 1984, is changed as follows:

1. Remove old pages and insert new pages as indicated below. New or changed material is indicated by a vertical bar in the margin of the page.

Remove pages
9 and 10

Insert pages
9 and 10

2. File this change in front of the publication for reference purposed.

By Order of the Secretary of the Army:

Official:

CARL E. VUONO
General, United States Army
Chief of Staff

WILLIAM J. MEEHAN II
Brigadier General, United States Army
The Adjutant General

Distribution:

To be distributed in accordance with DA Form 13-34C, Block No. 319, requirements for calibration procedures publications.

PIN: 051013-004

TB 9-6625-2071-35

CHANGE 3

DEPARTMENT OF THE ARMY TECHNICAL BULLETIN

CALIBRATION PROCEDURE FOR FREQUENCY COUNTER, AN/USM-459 (TS-3662/U) AND HEWLETT-PACKARD, MODELS 5328A/H42, 5328AMOD, 5328AF096, AND 5328A W/OPTIONS

Headquarters, Department of the Army, Washington, DC
2 February 1989

TB 9-6625-2071-35, 24 April 1984, is changed as follows:

1. Remove old pages and insert new pages as indicated below. New or changed material is indicated by a vertical bar in the margin of the page.

Remove pages
5 and 6

Insert pages
5 and 6

2. File this change in front of the publication for reference purposed.

By Order of the Secretary of the Army:

Official:

CARL E. VUONO
General, United States Army
Chief of Staff

WILLIAM J. MEEHAN II
Brigadier General, United States Army
The Adjutant General

Distribution:

To be distributed in accordance with DA Form 13-34C, Block No. 319, requirements for calibration procedures publications.

PIN: 051013-003

TB 9-6625-2071-35

CHANGE 2

DEPARTMENT OF THE ARMY TECHNICAL BULLETIN

**CALIBRATION PROCEDURE FOR
FREQUENCY COUNTER, AN/USM-459 (TS-3662/U)
AND HEWLETT-PACKARAD, MODELS 5328A/H42,
5328AMOD, 5328AF096, AND 5328A W/OPTIONS**

Headquarters, Department of the Army, Washington, DC
12 June 1987

TB 9-6625-2071-35, 24 April 1984, is changed as follows:

1. Remove old pages and insert new pages as indicated below. New or changed material is indicated by a vertical bar in the margin of the page.

Remove pages
5 through 8

Insert pages
5 through 8

2. File this change sheet in front of the publication for reference purposes.

By Order of the Secretary of the Army:

Official:

JOHN A. WICKHAM, JR.
General, United States Army
Chief of Staff

R. L. DILWORTH
Brigadier General, United States Army
The Adjutant General

Distribution:

To be distributed in accordance with DA Form 12-34C, Block No. 319, requirements for calibration procedures publications.

PIN: 051013-002

TB 9-6625-2071-35

CHANGE 1

DEPARTMENT OF THE ARMY TECHNICAL BULLETIN

CALIBRATION PROCEDURE FOR FREQUENCY COUNTER, AN/USM-459 (TS-3662/U AND HEWLETT-PACKARD, MODELS 5328A/H42, 5328AMOD, 5328AF096, AND 5328A W/OPTIONS

Headquarters, Department of the Army, Washington, DC
15 January 1986

TB 9-6625-2071-35, 24 April 1984, is changed as follows:

1. Remove old pages and insert new pages as indicated below. New or changed material is indicated by a vertical bar in the margin of the page.

Remove pages

1 and 2
5 through 10
15 and 16

Insert pages

1 and 2
5 through 10
15 and 16

2. File this change sheet in front of the publication for reference purposes.

By Order of the Secretary of the Army:

Official:

JOHN A. WICKHAM, JR.
General, United States Army
Chief of Staff

MILDRED E. HEDBERG
Brigadier General, United States Army
The Adjutant General

Distribution:

To be distributed in accordance with DA Form 12-34C, Block No. 319, requirements for calibration procedures publications.

PIN: 051013-001

***TB 9-6625-2071-35**

DEPARTMENT OF THE ARMY TECHNICAL BULLETIN

CALIBRATION PROCEDURE FOR FREQUENCY COUNTER, AN/USM-459 (TS-3662/U) AND HEWLETT- PACKARD, MODELS 5328A/H42, 5328AMOD, 5328AF096, and 5328A W/OPTIONS

Headquarters, Department of the Army, Washington, DC
24 April 1984

REPORTING OF ERRORS AND RECOMMENDED IMPROVEMENTS

You can help improve this publication. If you find any mistakes or if you know of a way to improve the procedure, please let us know. Mail your letter or DA Form 2028 to: Commander, U. S. Army Aviation and Missile Command, ATTN: AMSAM-MMC-MA-NP, Redstone Arsenal, AL 35898-5230. A reply will be furnished to you. You may also send in your comments electronically to our e-mail address: 2028@redstone.army.mil or by FAX (256) 842-6546/DSN 788-6546

SECTION		Paragraph	Page
	I. IDENTIFICATION AND DESCRIPTION		
	Test instrument identification.....	1	2
	DA Form 2416 (Calibration Data Card).....	2	2
	Calibration description.....	3	2
	II. EQUIPMENT REQUIREMENTS		
	Equipment required.....	4	3
	Accessories required.....	5	3
	III. CALIBRATION PROCESS		
	Preliminary instructions.....	6	5
	Equipment setup.....	7	5
	Time base stability.....	8	6
	Channel A sensitivity.....	9	8
	Channel B sensitivity.....	10	9
	Channel C sensitivity (AN/USM-459, model 5328AF096, and option 030).....	11	11
	Digital voltmeter (option 021).....	12	12
	Remote trigger level (AN/USM-459, model 5328AF096, and option 041).....	13	13
	Final procedure.....	14	19

CHANGE 5

*This bulletin supersedes TB 9-6625-2071-35, 17 May 1982.

**SECTION I
IDENTIFICATION AND DESCRIPTION**

1. Test Instrument Identification. This bulletin provides instructions for the calibration of Frequency Counter, AN/USM459 (TS-3662/U) and Hewlett-Packard, Models 5328A/H42, 5328AMOD, 5328AF096, and 5328A w/Options. The manufacturers' manuals were used as the prime data sources in compiling these instructions. The equipment being calibrated will be referred to as the TI (test instrument) throughout this bulletin.

a. Model Variations

(1) Model 5328A frequency counter may have the following options:

- 010 Oven Controlled Crystal (Oscillator).
- 011 IEEE-488 Interface
- 021 High Performance DVM.
- 030 Channel C Frequency Measurement to 512 MHz.
- 041 Programmable A and B Inputs.
- H60 Rear A and B Inputs.

(2) Models 5328A/H42, 5328AMOD, AN/USM-459, and TS-3662/U are equivalent to model 5328A frequency counter w/options 010, 011, 030, and 041.

(3) Models 5328AF096 (5328A/H99) and 5328A/H42 are alike for calibration purposes.

b. Time and Technique. The time required for this calibration is approximately 4 hours, using the dc and low frequency technique.

2. DA Form 2416 (Calibration Data Card)

a. Forms, records, and reports required for calibration personnel at all levels are prescribed by TB 750-25. DA Form 2416 must be annotated in accordance with TB 750-25 for each calibration performed.

b. Adjustments to be reported on DA Form 2416 are designated (R) at the end of the sentence in which they appear. When adjustments are in tables, the (R) follows the designated adjustment. Report only those adjustments made and designated with (R).

3. Calibration Description. TI parameters and performance specifications which pertain to this calibration are listed in table 1.

Table 1. Calibration Description

Test Instrument Parameters	Performance Specifications
Time base stability: Model 5328A	Frequency: 10 MHz Aging rate: <3 x 10 ⁻⁷ /month Line voltage stability (for 10% variation): <±1 X 10 ⁻⁷
Models 5328A option 010, 5328AF096 and AN/USM-459	Frequency: 10 MHz Aging rate (after 24 hr warm-up): <5 X 10 ⁻¹⁰ /day Line voltage stability (for 10% variation): <±5 X 10 ⁻⁹

Table 1. Calibration Description - Continued

Test Instrument Parameters	Performance Specifications
Channel A and B sensitivity: Model 5328A and option 041 Model 5328AF096 and AN/USM-459	25 mV rms: Dc to 40 MHz (dc coupled) 20 Hz to 40 MHz (ac coupled) 50 mV rms: 40 to 100 MHz 15 mV rms: Dc to 35 MHz (dc coupled) 20 Hz to 35 MHz (ac coupled) 50 mV rms: 35 to 100 MHz
Channel C sensitivity: Model 5328A option 030 Model 5328AF096 and AN/USM-459	15 mV rms: 5 to 512 MHz 15 mV rms: 30 to 500 MHz
Digital voltmeter: Model 5328A option 021	Range: 10, 100, 1000 V dc and AUTO Accuracy: 10, 100 V ranges: $\pm 0.03\%$ of reading $\pm 0.004\%$ of range 1000 V range: $\pm 0.087\%$ of reading $\pm 0.004\%$ of range
Remote trigger levels: Models 5328A option 041, 5328AF096 and AN/USM-459	Range: -2 to +2 V Accuracy: ± 35 mV

**SECTION II
EQUIPMENT REQUIREMENTS**

4. Equipment Required. Table 2 identifies the specific equipment to be used in this calibration procedure. This equipment is issued with Secondary Transfer Calibration Standards Set AN/GSM-286. Alternate items may be used by the calibrating activity when the equipment listed in table 2 is not available. The items selected must be verified to perform satisfactorily prior to use and must bear evidence of current calibration. The equipment must meet or exceed the minimum use specifications listed in table 2. The accuracies listed in table 2 provide a four-to-one ratio between the standard and TI.

5. Accessories Required. The accessories listed in table 3 are issued as indicated in paragraph 4 above and are used in this calibration procedure. When necessary, these items may be substituted by equivalent items, unless specifically prohibited.

TB 9-6625-2071-35

Table 2. Minimum Specifications of Equipment Required

Item	Common name	Minimum use specifications	Manufacturer and model (part number)
A1	AUTOTRANSFORMER	Range: 105 to 125 V ac Accuracy: $\pm 1\%$	General Radio, Model W10MT3AS3 or Ridge, Model 9020F (7910809)
A2	CONTROLLER ¹	Must be compatible with Hewlett-Packard-IB interface (option 011)	John Fluke, Model 1720A w/keyboard and system disk (part of John Fluke 5100B calibrator system)
A3	DC VOLTAGE STANDARD	Range: -9.5033 to 950.33 V dc Accuracy: $\pm 0.0085\%$	John Fluke, Model 332B/AF (332B/AF)
A4	DIGITAL VOLTMETER	Range: -2 to +2 V dc Accuracy: $\pm 0.01\%$	Hewlett-Packard, Model 3490AOPT060 (3490AOPT060)
A5	FREQUENCY DIFFERENCE METER	Resolution: 1 part in 10^{10}	Tracor, Model 527E (527E)
A6	OSCILLOSCOPE	Vertical: 5 mV to 6 V ac Horizontal: 100 Hz to 20 kHz Accuracy: $\pm 3\%$	Tektronix, Type R5440 (MIS-28706/1 Type 1) w/5A48 (MIS-28706/3) and 5B42 (MIS-28706/4)
A7	RESISTANCE STANDARD	Range: 100 Ω Accuracy: $\pm 1\%$	Biddle-Gray, Model 601147-1(7910328)
A8	SIGNAL GENERATOR	Range: 5 to 512 MHz Amplitude: 0 to 50 mV Accuracy: ± 2 dB	Hewlett-Packard, Model 8640B-OPTH66 (MIS-28707 Type 1)
A9	STANDARD OSCILLATOR	Range: 1 MHz Accuracy: 5 parts in 10^{10} per day	Hewlett-Packard, Model 105AOPT908 (APTAOPT908)
A10	TEST OSCILLATOR	Range: 10 Hz to 10 MHz Amplitude: 0 to 3.16 V Accuracy: $\pm 3\%$	Hewlett-Packard, Model 652A (MIS-10224)

¹Limited deployment item.

Table 3. Accessories Required

Item	Common name (official nomenclature)	Description (part number)
B1	ADAPTER ¹	BNC T-type, 2 jacks, 1 plug (MS35173-274C)
B2	ADAPTER	BNC jack terminations (MS35184-914)
B3	ADAPTER	N plug to BNC jack (10519457) (UG201A/U)
B4	ADAPTER ¹	BNC plug to double banana jacks (7909401) (UG1441/U)
B5	CABLE ²	IEEE 488 (part of JF 5100B calibrator system)
B6	CABLE ¹	30-in., RG-58/U; double banana plug terminations (7907470)
B7	CABLE ³	30-in., RG-58/U; BNC plug terminations (7907467)
B8	CABLE (TEST LEAD)	36-in., RG-58/U; BNC plug to double banana plug terminations (7907471)
B9	CAPACITOR	1 μ F non-polarized (obtain locally)
B10	LEAD ¹	4-in., No. 18; single banana plug terminations (black) (7907492)
B11	TERMINATION ¹ (DUMMY LOAD)	50 Ω feed-through; BNC plug to BNC jack (11048B)

¹Two required.

²Limited deployment item.

³Three required.

SECTION III CALIBRATION PROCESS

6. Preliminary Instructions

a. The instructions outlined in paragraphs **6** and **7** are preparatory to the calibration process. Personnel should become familiar with the entire bulletin before beginning the calibration.

b. Items of equipment used in this procedure are referenced within the text by common name and item identification number as listed in tables 2 and 3. For the identification of equipment referenced by item numbers prefixed with A, see table 2, and for prefix B, see table 3.

WARNING

HIGH VOLTAGE is used or exposed during the performance of this calibration. DEATH ON CONTACT may result if personnel fail to observe safety precautions.

NOTE

Unless otherwise specified, verify the result of each test and, whenever the test requirement is not met, take corrective action before continuing with the calibration. Adjustments required to calibrate the TI are included in this procedure. Additional maintenance information is contained in the manufacturers' manuals for this TI.

NOTE

Unless otherwise specified, all controls and control settings refer to the TI.

7. Equipment Setup

a. Remove TI protective cover as needed to make adjustments.

b. Connect TI to autotransformer (A1)

c. Connect autotransformer to 115 V-ac source and adjust output to 115 V.

d. Set power switch to ON and allow at least 1 hour for stabilization. If TI has been disconnected from line power for more than 24 hours, allow at least 24 hours for warm-up before beginning calibration.

e. Position controls as listed in (1) through (12) below:

(1) FUNCTION switch to FREQ A.

(2) FREQ RESOLUTION N switch to 1 Hz, 10^6 .

TB 9-6625-2071-35

- (3) SAMPLE RATE control fully ccw.
- (4) LEVEL A and LEVEL B controls to PRESET.
- (5) CHANNEL A and B DC-AC switches to DC.
- (6) CHANNEL A and B ATTEN switches to X1.
- (7) CHANNEL A and B SLOPE switches to + (positive).
- (8) COM A/SEP switch to SEP.
- (9) 1 M Ω /50 Ω switch to 1 M Ω (option 041).
- (10) ARM switch (rear panel) to OFF.
- (11) OSC switch (rear panel) to INT (model 5328A).
- (12) CHANNEL A and B rear inputs terminated with 50 Ω loads supplied with TI (option H60).

8. Time Base Stability**a. Performance Check**

- (1) Connect 1 MHz output of standard oscillator (A9) to REF INPUT of frequency difference meter (A5), using cable (B7).
- (2) Connect FREQ STD OUTPUT jack (rear panel) or 10 MHz OUT jack (AN/USM459 and model 5328AF096) to SIG INPUT of frequency difference meter, using cable (B7).
- (3) Model 5328A, adjust OSC ADJ (A1C18) (fig. 1) for minimum difference indication on frequency difference meter. Model 5328A option 010, adjust FREQ ADJ (fig. 1) for minimum difference indication on frequency difference meter. Model 5328AF096 and AN/USM-459, adjust FREQ ADJ (fig. 1) and A3R14 (fig. 1) for minimum difference indication on frequency difference meter. Frequency difference meter will indicate less than 3 parts in 10^7 model 5328A (5 parts in 10^{10} ; models 5328A option 010, 5328AF096 and AN/USM-459) after 24-hour stabilization.
- (4) Adjust output of autotransformer from 105 to 125 V ac and verify that TI oscillator drift is less than 1 part in 10^7 model 5328A (5 parts in 10^9 , models 5328A option 010, 5328AF096, and AN/USM-459).

Figure 1. Test instrument - top view.

- ✓ 5328A
- 2/ ✓ 5328A OPT 010
- 3/ ✓ 5328A OPT 021
- 4/ ✓ 5328A OPT 030
- 5/ ✓ 5328A OPT 041
- 6/ ✓ AN/USM-489
- 7/ ✓ 5328AF096

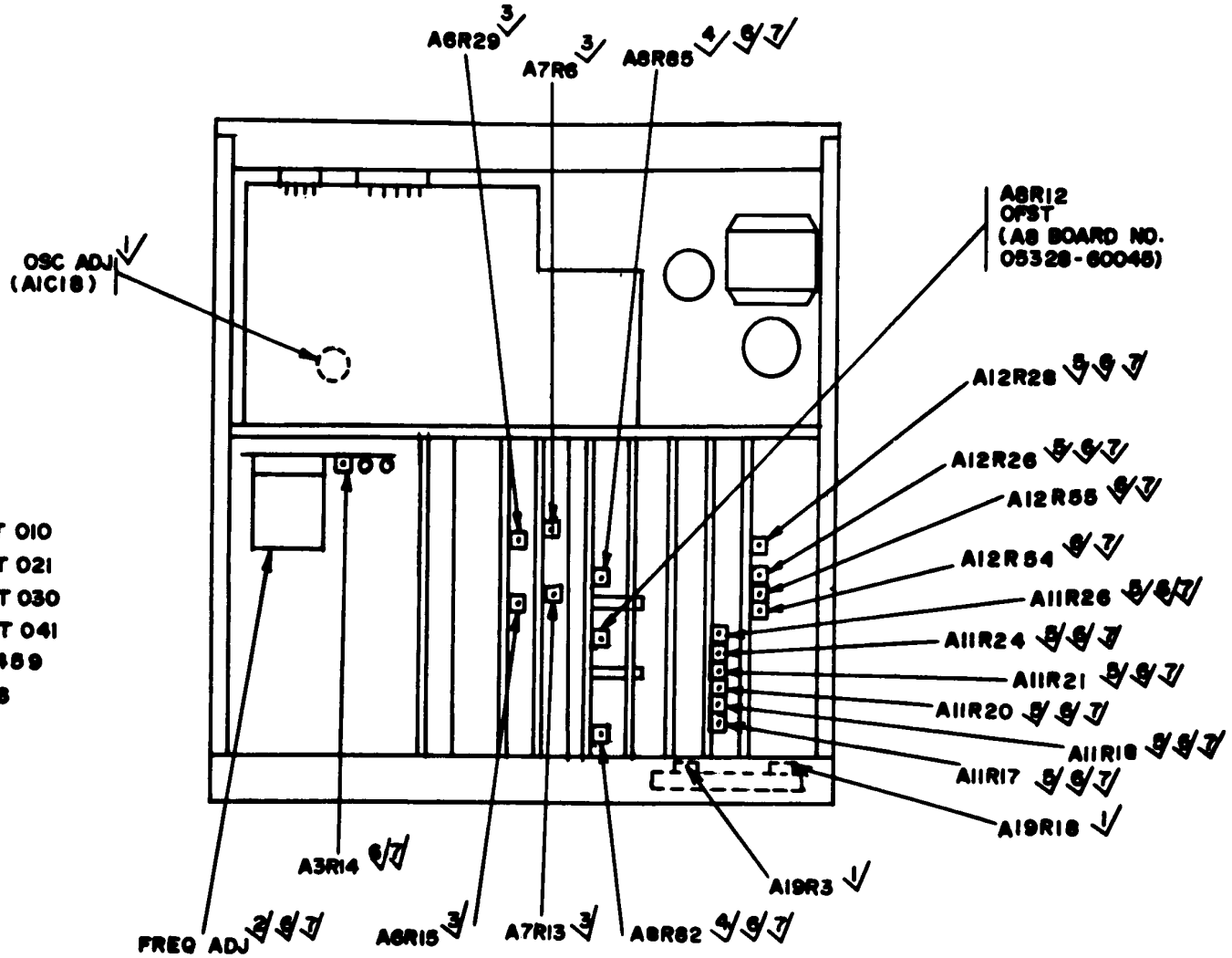

TB 9-6625-2071-35

NOTE

It may be necessary to wait 5 minutes after each voltage change for oscillator to stabilize (option 010)

(5) Adjust output of autotransformer for 115 V ac.

b. Adjustments. No further adjustments can be made.

9. Channel A Sensitivity

a. Performance Check

(1) Connect test oscillator (A10) 50 Ω output to INPUT A, using cable and termination (B7 and B11). (Omit termination w/option H60.)

(2) Set test oscillator frequency to 10 kHz and slowly increase output until TI displays a stable indication of applied frequency. If test oscillator output exceeds 25 mV (15 mV; AN/USM-459 and model 5328AF096), perform **b** below.

(3) Repeat technique of (2) above, varying test oscillator frequency from 10 Hz to 10 MHz.

(4) Set DC-AC switch to AC.

(5) Repeat technique of (2) above, varying test oscillator frequency from 20 Hz to 10 MHz.

(6) Set FREQ RESOLUTION N switch to 10 Hz, 10⁵.

(7) Substitute signal generator (A8) for test oscillator, using adapter, cable, and termination (B3, B7, and B11). (Omit termination w/option H60.)

(8) Repeat technique of (2) above, varying signal generator frequency from 10 to 100 MHz. Signal generator output will not exceed 25 mV (10 to 40 MHz) or 50 mV (40 to 100 MHz AN/USM-459 and model 5328AF096, 15 mV (10 to 35 MHz) or 50 mV (35 to 100 MHz).

(9) Set DC-AC switch to DC and repeat (8) above.

b. Adjustments

NOTE

AN/USM-459 and model 5328AF096 perform only **b**(5) through (9) below.

(1) Substitute signal generator (A8) for test oscillator, using adapter, cable, and termination (B3, B7, and B11). (Omit termination w/option H60.)

- (2) Set signal generator frequency to 40 MHz and output to 25 mV.
- (3) Adjust A19R3 (fig. 1) or A12R26 (option 041) for a stable indication of applied frequency (R).
- (4) Slowly decrease signal generator output and repeat (3) above.

NOTE

Do not adjust sensitivity below 10 mV.

- (5) Connect oscilloscope (A6) CH 1 input to CHANNEL A MARKER OUTPUT, using cable and termination (B7 and B11).
- (6) Position oscilloscope controls as listed in (a) through (e) below;
 - (a) CH 1 VOLTS/DIV switch to 1.
 - (b) AC/DC coupling pushbutton in.
 - (c) MAIN SEC/DIV switch to 10 μ SEC.
 - (d) SLOPE pushbutton in.
 - (e) MAIN SWP pushbutton in.
- (7) Set test oscillator frequency to 10 kHz and output to 15 mV.
- (8) Adjust A12R26 (fig. 1) for a symmetrical squarewave on oscilloscope (R).
- (9) Adjust A12R55 (fig. 1) for a stable indication of applied frequency (R).

10. Channel B Sensitivity

a. Performance Check

- (1) Set FUNCTION switch to RATIO B/A.
- (2) Set CHANNEL A ATTEN switch to X10 and DC-AC switch to AC.
- (3) Connect FREQ STD OUTPUT jack (rear panel) or 10 MHz OUT jack (AN/USM459 and model 5328AF096) to INPUT A, using cable and termination (B7 and B11).
- (4) Connect test oscillator 50 Ω output to INPUT B, using cable and termination (B7 and B11). (Omit termination w/option H60.)

NOTE

In (5) through (7) below, the TI indications are not critical but should be stable. Only the channel B input sensitivity is being checked.

(5) Set test oscillator frequency to 10 kHz and slowly increase output until TI displays a stable reading of 0.00100. If test oscillator output exceeds 25 mV (15mV AN/USM-459 and model 5328AF096), perform **b** below.

(6) Repeat technique of (5) above, using values listed in table 4. Test oscillator or signal generator output will not exceed 25 mV (10 Hz to 40 MHz) or 50 mV (40 to 100 MHz); AN/USM-459 and model 5328AF096, 15 mV (10 Hz to 35 MHz) or 50 mV (35 to 100 MHz).

Table 4. Channel B Sensitivity

Test oscillator signal generator frequencies	Test instrument indications
10 Hz ¹	0.000001
100 Hz	0.00001
1 kHz	0.00010
100 kHz	0.01000
1 MHz	0.10000
10 MHz	1.00000
20 MHz ²	2.00000
30 MHz	3.00000
40 MHz	4.00000
60 MHz	6.00000
80 MHz	8.00000
90 MHz	9.00000
100 MHz	10.00000

¹Set **FREQ RESOLUTION N** switch to 1 Hz, 10⁶ for 10 and 20 Hz only.

²Substitute signal generator for test oscillator, using adapter, cable, and terminations (B3, B7, and B11). (Omit termination w/option H60).

(7) Set **CHANNEL B DC-AC** switch to **DC** and repeat (5) and (6) above, substituting 20 Hz for 10 Hz and 0.000002 for 0.000001 in table 4.

b. Adjustments

NOTE

AN/USM-459 and model 5328AF096, perform only **b(5)** through (9) below.

(1) Substitute signal generator for test oscillator, using adapter, cable, and termination (B3, B7, and B11). (Omit termination w/option H60.)

(2) Set signal generator frequency to 40 MHz and output to 25 mV.

- (3) Adjust A19R18 (fig. 1) or A12R28 (option 041) for a stable indication of 4.00000 (R).

NOTE

Do not adjust sensitivity below 10 mV.

- (4) Connect oscilloscope (A6) **CH 1** input to **CHANNEL B MARKER OUTPUT**, using cable and termination (B7 and B11).

- (5) Position oscilloscope controls as listed in (a) through (e) below:

- (a) **CH 1 VOLTS/DIV** switch to **1**.
- (b) **AC/DC COUPLING** pushbutton in.
- (e) **MAIN SEC/DIV** switch to **10 mSEC**.
- (d) **SLOPE** pushbutton in.
- (e) **MAIN SWP** pushbutton in.

- (6) Set test oscillator frequency to 10 kHz and output to 15 mV.

- (7) Adjust A12R28 (fig. 1) for a symmetrical square wave on oscilloscope (R).

- (8) Adjust A12R28 (fig. 1) for a stable indication of 0.00100 (R).

11. Channel C Sensitivity (AN/USM-459, Model 5328AF096, and Option 030)

a. Performance Check

- (1) Connect signal generator to **CHANNEL C** input, using adapter and cable (B3 and B7)

- (2) Set **FUNCTION** switch to **FREQ C**.

- (3) Set **FREQ RESOLUTION N** switch to .1 kHz, 10^4 .

- (4) Set signal generator frequency to 100 MHz and slowly increase output until TI displays a stable indication of applied frequency. If signal generator output exceeds 15 mV, perform **b** below.

- (5) Repeat technique of (4) above, varying signal generator frequency from 5 to 512 MHz (AN/USM-459 and model 5328AF096, 30 to 500 MHz).

b. Adjustments

TB 9-6625-2071-35

NOTE

For serial number prefix 2138A and greater containing A8 board number 05328-60045, perform only **b(5)** below.

(1) Decrease signal generator output to 15 mV while adjusting A8R82 (fig. 1) until TI displays a stable indication of applied frequency (R).

(2) Set signal generator frequency to 500 MHz and output to 50 mV.

(3) Decrease signal generator output until display is no longer stable.

(4) Adjust A8R85 (fig. 1) until TI displays a stable indication of applied frequency (R).

(5) Decrease signal generator output to 15 mV while adjusting A8R12OFST (fig. 1) until TI displays a stable indication of applied frequency (R).

12. Digital Voltmeter (Option 021)

a. Performance Check

(1) Position controls as listed in (a) through (e) below:

(a) FUNCTION switch to DVM.

(b) FREQ RESOLUTION N switch, to 1 Hz, 10^6 .

(c) DCV RANGE switch to AUTO.

(d) FILTER switch to OFF.

(e) READ A and READ B pushbuttons out.

(2) Connect short between HI and LO inputs, using lead (B10). If TI display does not indicate $0.0000\text{ V} \pm 0.4\text{ mV}$, perform **b(1)** below.

(3) Connect dc voltage standard (A3) to HI and LO inputs, using cable (B6).

(4) Adjust dc voltage standard for a +9.500-V indication on TI display. If dc voltage standard does not indicate between +9.4967 and +9.5033, perform **b(2)** and (3) below.

(5) Repeat technique of (4) above, using values listed in table 5. If dc voltage standard does not indicate within limits specified, perform **b(4)** below.

Table 5. Digital voltmeter Check

Test instrument indications (V)	Dc voltage standard indications (V)		Adjustments (fig. 1) (R)
	Min	Max	
-9.5000	-9.5033	-9.4967	A7R6
+95.000	+94.967	+95.033	A6R29
+950.00	+949.13	+950.87	A6R15

b. Adjustments

(1) Adjust A6R28 (DVM zero adjustment) through access hole on front panel for a display of 0.0000 ± 1 count (R).

(2) Set dc voltage standard to +9.500 V.

(3) Adjust A7R13 (fig. 1) for a display of $+9.5000 \pm 1$ count (R).

(4) Repeat technique of (2) and (3) above, using indications and adjustments listed in table 5.

13. Remote Trigger Level (AN/USM-459, Model 5328AF096, and Option 041)

a. Performance Check

NOTE

This paragraph to be performed only if TI is used in a programmed configuration and controller (A2) is available. If the PERSHING SUPPORT DISC is available, use it in conjunction with this paragraph.

(1) Connect equipment as shown in figure 2, connection A.

(2) Position oscilloscope (A6) controls as listed in (a) through (h) below:

(a) CH 1 VOLTS/DIV switch to 0.5.

(b) CH 1 AC-DC pushbutton out.

(c) CH 2 VOLTS/DIV switch to 1.0.

(d) CH 2 AC-DC pushbutton in.

(e) CH 2 POSITION control to center sweep on screen.

(f) Press DUAL TRACE pushbuttons.

(g) Press CH 2 TRIGGER pushbuttons.

(h) Set MAIN SEC/DIV switch to 2 mSEC.

(3) Set test oscillator frequency to 100 Hz and output to 6 V p-p as indicated on oscilloscope CH 2 sweep.

(4) Insert system disk into controller (A2) and press RESTART pushbutton.

(5) After controller loads disk, insure display displays the following:

BASIC VERSION 1.2

READY

(6) Program controller as listed in (a) through (c) below. Press the RETURN key after each sentence.

(a) INIT PORT Ø

(b) REMOTE@1.

(c) PRINT@1,"PF4G6S13A379+ØØ Ø*B37+ØØØ*R"

(7) Position oscilloscope CH 1 sweep so that top marker of CH 1 sweep just barely intersects the leading and trailing edges of CH 2 sweep. If this intersection does not occur at 0 V, ± 35 mV, as shown in figure 3a, perform **b** below.

(8) Connect equipment as shown in figure 2, connection A.

(9) Repeat (7) above.

(10) Program controller as follows: PRINT@1,"PF4G6S13A379+ 2ØØ*B37+ 2ØØ*R".

(11) Repeat technique of (7) above. If this intersection does not occur at + 2.00 V , ± 35 mV, as shown in figure 3b, perform **b** below.

(12) Connect equipment as shown in figure 2, connection A.

(13) Repeat (11) above.

(14) Program controller as follows: PRINT@1, "PF4G6S13A379-2ØØ*B37-2ØØ*R".

(15) Repeat technique of (7) above. If this intersection does not occur at -2.00 V, ± 35 mV, as shown in figure 3c, perform **b** below.

(16) Connect equipment as shown in figure 2, connection B.

(17) Repeat (15) above.

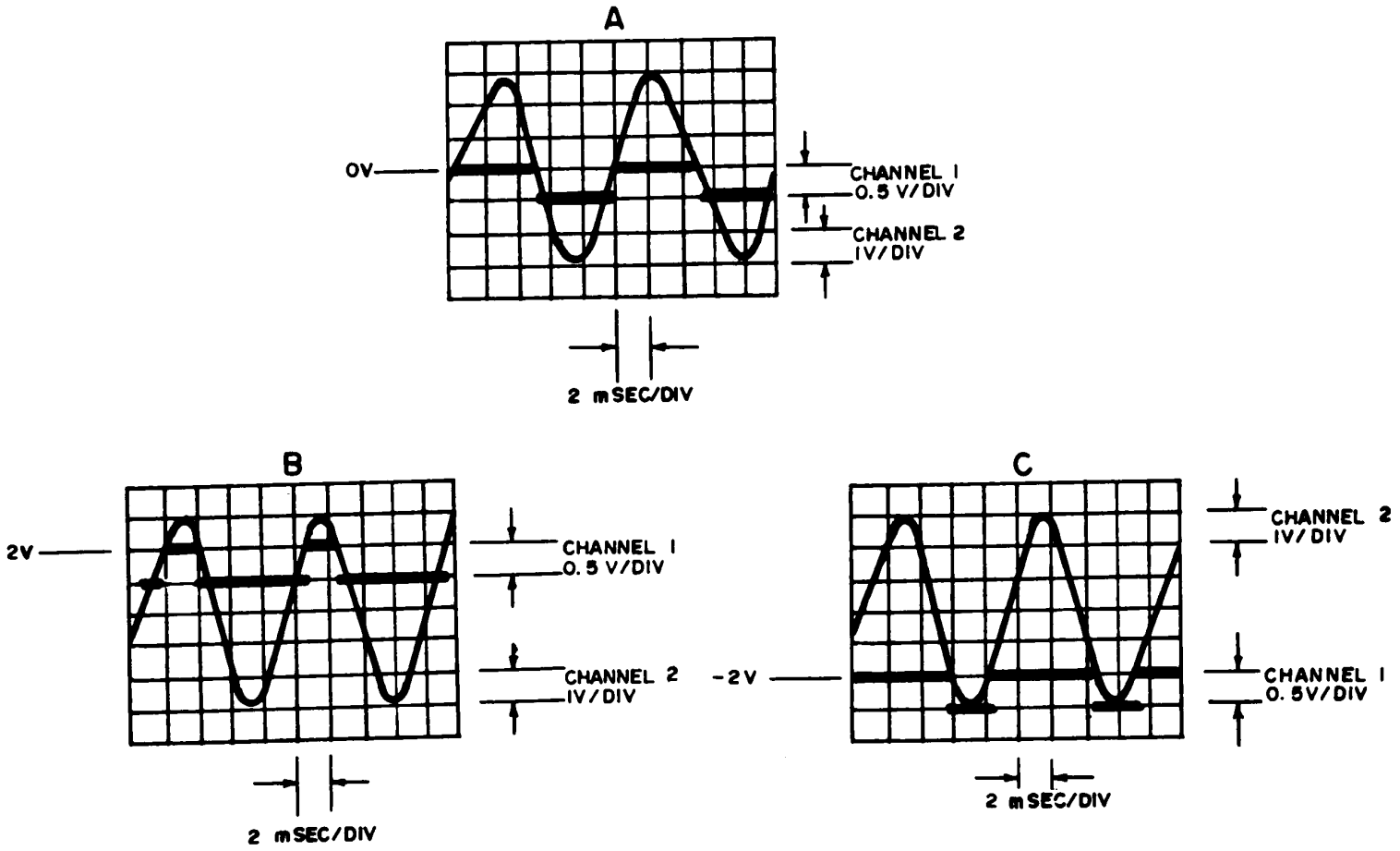

Figure 3. Remote trigger levels.

b. Adjustments

- (1) Connect equipment as shown in figure 4, connection A.

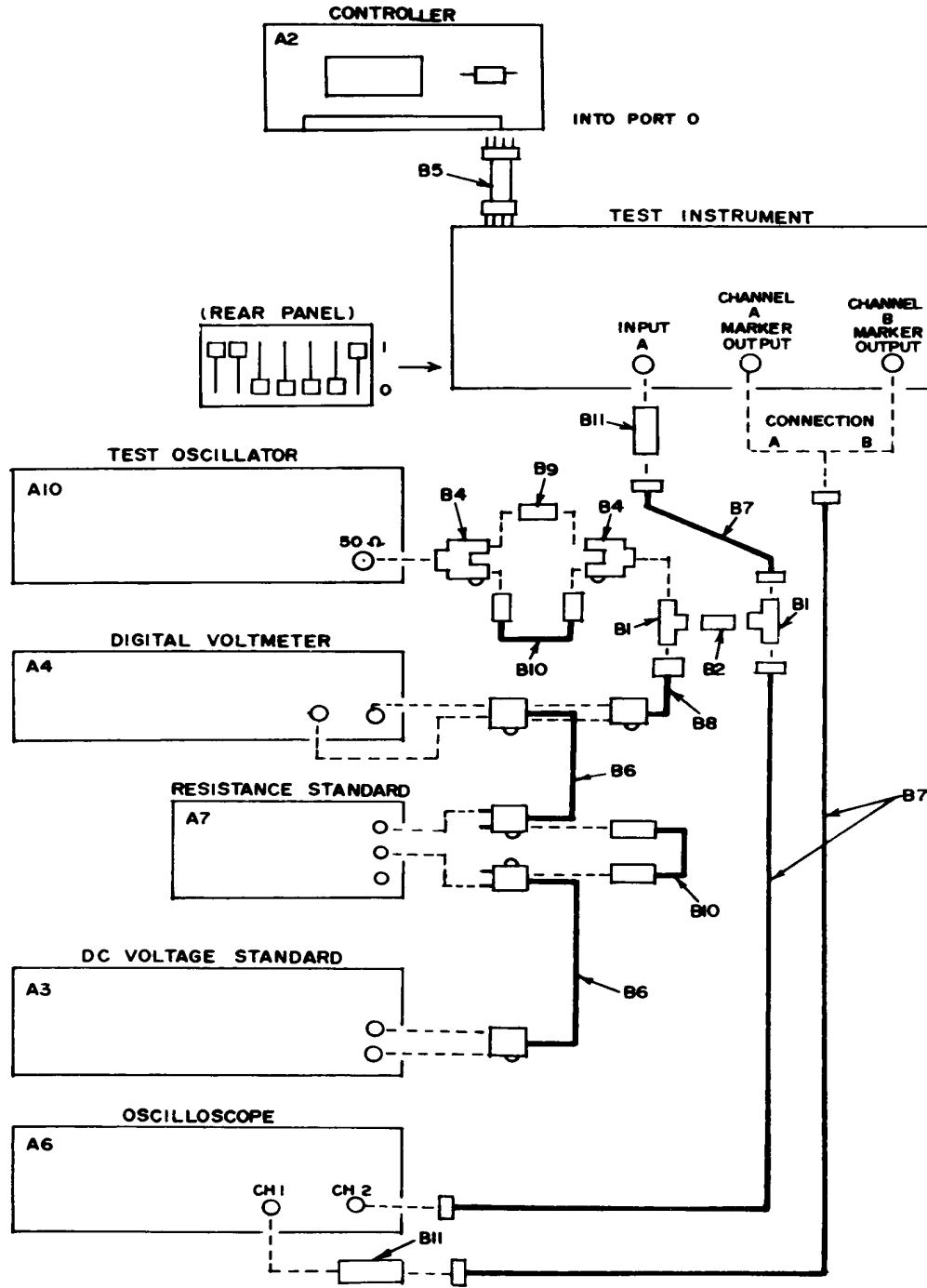

Figure 4. Trigger level adjustment - equipment setup.

TB 9-6625-2071-35

- (2) Position oscilloscope controls as listed in **(a)** and **(b)** below:
 - (a) CH 2 VOLTS/DIV switch to 10 MV.
 - (b) Set MAIN SEC/DIV switch to 10 μ SEC.
- (3) Set test oscillator frequency to 20 kHz and output to 70 mV p-p as indicated on oscilloscope CH 2 sweep.
- (4) Program controller as follows: PRINT@1,"PF4G6S13A379+ $\emptyset\emptyset\emptyset$ *B37+ $\emptyset\emptyset\emptyset$ *R".
- (5) Adjust dc voltage standard (A3) for a 0.00000-V indication on digital voltmeter (A4).
- (6) Adjust A11R21 (fig. 1) for a 50 percent duty cycle as indicated on oscilloscope CH 1 sweep (R).
- (7) Connect equipment as shown in figure 4, connection B.
- (8) Adjust A11R20 (fig. 1) for a 50 percent duty cycle as indicated on oscilloscope CH 1 sweep (R).
- (9) Connect equipment as shown in figure 4, connection A.
- (10) Program controller as follows: PRINT@1,"PF4G6S13A379+2 $\emptyset\emptyset$ *B37+2 $\emptyset\emptyset$ *R".
- (11) Adjust dc voltage standard for a + 2.00000-V indication on digital voltmeter.
- (12) Adjust A11R24 (fig. 1) for a 50 percent duty cycle as indicated on oscilloscope CH 1 sweep (R).
- (13) Connect equipment as shown in figure 4, connection B.
- (14) Adjust A11R18 (fig. 1) for a 50 percent duty cycle as indicated on oscilloscope CH 1 sweep (R).
- (15) Connect equipment as shown in figure 4, connection A.
- (16) Program controller as follows: PRINT@1,"PF4G6S13A379-2 $\emptyset\emptyset$ *B37-2 $\emptyset\emptyset$ R".
- (17) Adjust dc voltage standard for a -2.00000-V indication on digital voltmeter.
- (18) Adjust A11R26 (fig. 1) for a 50 percent duty cycle as indicated on oscilloscope CH 1 sweep (R).

(19) Connect equipment as shown in figure 4, connection B.

(20) Adjust A11R17 (fig. 1) for a 50 percent duty cycle as indicated on oscilloscope CH 1 sweep (R).

14. Final Procedure

a. Deenergize and disconnect all equipment and reinstall TI protective cover.

b. When all parameters are within tolerance, annotate and affix DA Label 80 (US Army Calibrated Instrument). When the TI receives limited or special calibration, annotate and affix DA Label 163 (US Army Limited or Special Calibration). When the TI cannot be adjusted within tolerance, repair the TI in accordance with the maintenance manual. When repair is delayed for any reason or the TI cannot be repaired with local resources, annotate and affix DA Form 2417 (US Army Calibration System Rejected Instrument) and inform the owner/user accordingly in accordance with TB 750-25.

TB 9-6625-2071-35

By Order of the Secretary of the Army:

JOHN A. WICKHAM, JR.
General, United States Army
Chief Of Staff

Official:

ROBERT M. JOYCE
Major General, United States Army
The Adjutant General

Distribution:

To be distributed in accordance with DA Form 12-34C, Block 319, requirements for calibration procedures publications.

US GOVERNMENT PRINTING OFFICE: 1986-491-885/40003

PIN: 051013-006